

CAD FILE:

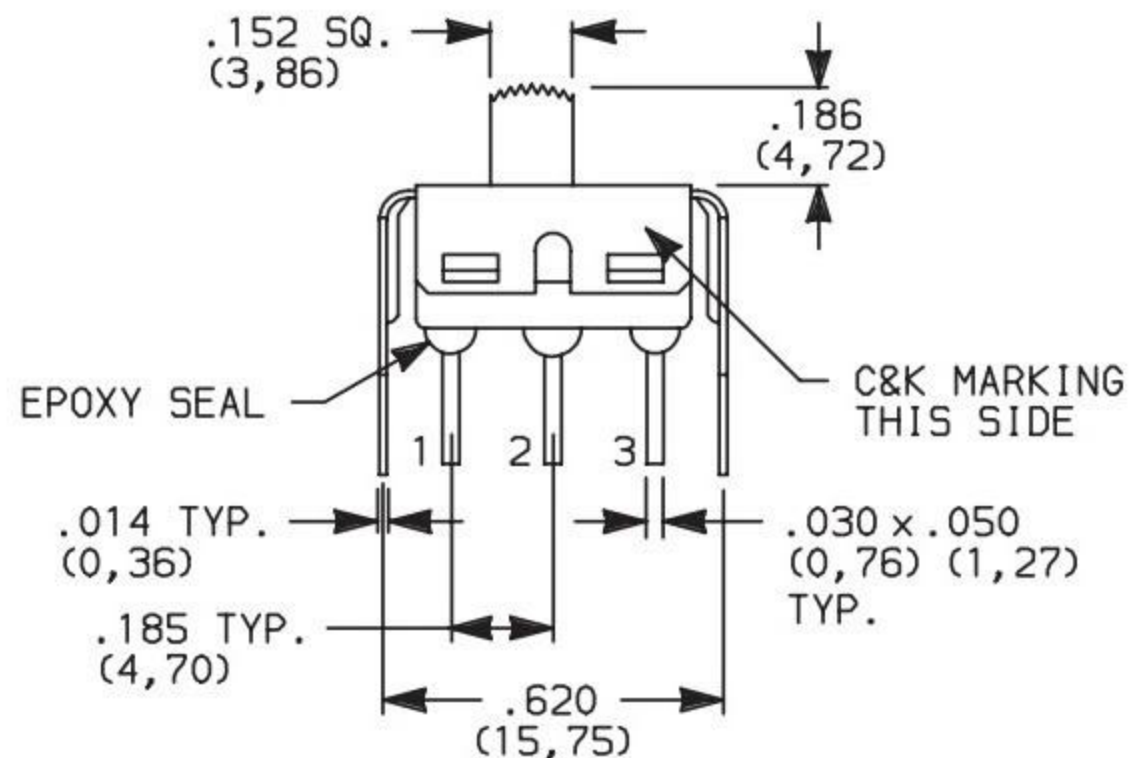

Actuator Shown In Pos. 1

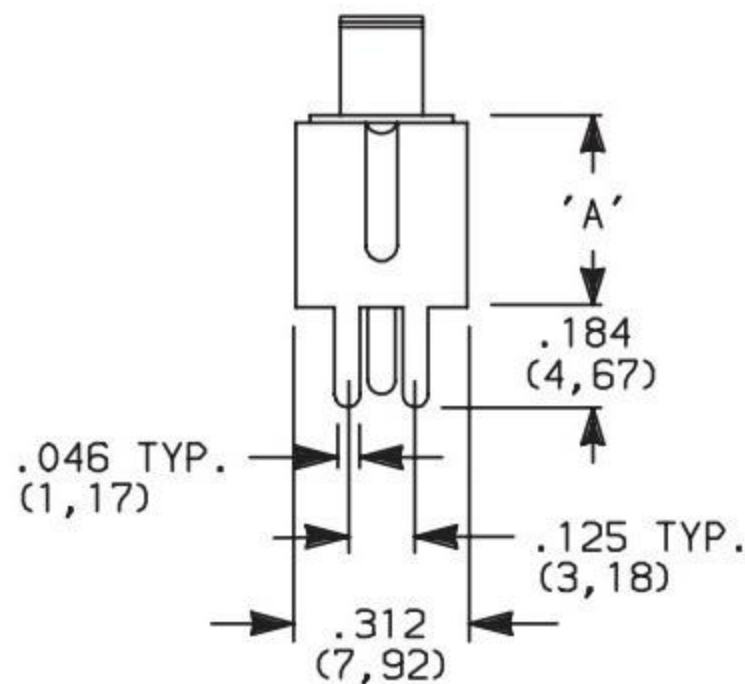

PC MOUNTING

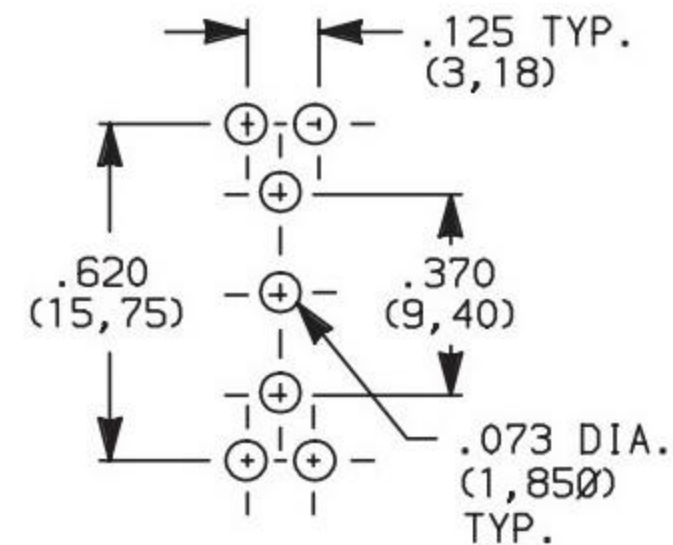

拨动开关立式技术参数:

1. 额定负荷: AC 125V 2A 3A
2. 接触阻抗:  $\leq 50m\Omega$
3. 绝缘阻抗:  $\geq 100m\Omega$  DC500V
4. 耐焊温度:  $250 \pm 5^\circ 5s$
5. 使用寿命: 10,000 cycles
6. 使用温度:  $-25^\circ C$  to  $80^\circ C$
7. 使用湿度:  $\leq 85\% RH$
8. 操作力: 160gf 256gf 300gf 可定制
9. 手柄长度: 2mm-10mm 可定制

注: "\*"表示关键尺寸(4个)

NO.	PARTS	MATERIALS	Q'TY	FINISH	TOLERANCE UNLESS SPECIFIED	ISSUE	DATE	DESCRIPTIONS OF REVISION	APPD.
8									
7	STEEL BALL	STEEL	1	NATURAL					
6	SPRING	STEEL WIRE	1	NATURAL		A	2012-10-28	初版	
5	CONTACT CLIP	PBS STRIP	2	Ag PLATED	WITHIN OVER				
4	TERMINAL	BRASS STRIP	8	Ag PLATED					
3	BASE	PHENOLIC RESIN	1	NATURAL					
2	FRAME	STEEL STRIP	1	Ni PLATED					
1	KNOB	POM	1	BLACK					
					TITLE : VERTICAL SLIDE SWITCH		UNIT : mm	DRWG NO.:	
					MODEL:		SCALE: 3:1	DWN.	2012-10-28
					<b>东莞市高迪电子有限公司</b>			CHK'D	
								APPD.	